

Corporate Profile

Wabash Mfg. Inc. is an Alberta based and privately owned company located in Westlock, AB, Canada.

Since 1981, Wabash has been recognized as a manufacturer of quality tanks, trailers, mining support equipment and a line of rural fire tender units.

Wabash presently employs over 100 people on its 20+ acre facility. Our staff includes full time Professional Engineers, MET`s, Welders, Mechanics, Millwrights, Painters, Parts Technicians, and Support Staff, that are trained and certified to industry standards. Wabash is certified for the manufacturing of Dangerous Goods Transport Equipment. Our manufacturing facility features shops dedicated to the manufacturing of oilfield and mining equipment. Materials for construction include mild steel, stainless steel aluminum and fiberglass. In addition to our manufacturing division, Wabash also stocks a large inventory of parts to service our customers` needs.

With customer focus as our mandate, we intend to continue to build relationships with our clients based on their needs, service requirements and expectations. We have a proven record of achievements and look forward to new opportunities and alliances to continue our growth for years to come.

Alberta, Canada



Mission Statement

Through progressive, innovative engineering and by accommodating the individual needs of our clients, Wabash Mfg. Inc. strives always to live up to the statement that has been our motto since 1981; "Quality products and services at fair prices".

Health & Safety Policy

Wabash Mfg. Inc. has a proactive Health & Safety Program that helps protect our staff, property and the general public from injury. Our Health & Safety Program follows the standards of practice of Government of Alberta Occupational Health & Safety, and incorporates on the job training to ensure all staff are educated about the dangers of the workplace. At Wabash Mfg. Inc., safety comes first.



We Are CanQual Certified



Wabash Mfg. Inc.
9312-110 A Street
Westlock, Alberta, Canada
T7P-2M4
Phone: 780-349-4282
Fax: 780-349-4716
www.wabash.ca
sales@wabash.ca

© Wabash Mfg. Inc., 2010



Custom
Design/Fabricated

Off-Highway Articulating Lube/Fuel Trucks

To Satisfy Client Specifications





Product Dispensing Cabinet

Diesel fuel tanks available in carbon steel or aluminum.

Oil and grease tanks are available in stainless steel, carbon steel or aluminum. All tanks are designed using the latest technologies including 3D modeling and Finite Element Analysis software.

Tank capacities can be adjusted to suit the customer's requirements.

Hose reels available with spring, electric or hydraulic retraction.

Filtration available on all oils and diesel fuel.

Ground level remote filling connections with high level indicators.

Digital fluid level monitors available.

Authorized Distributor for:



©Wabash Mfg. Inc., 2010

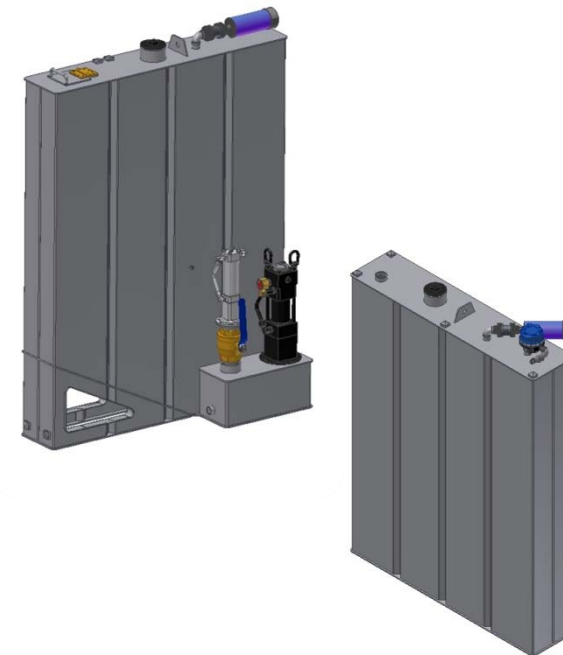

Product Tank

Wabash is proud to be affiliated with Caterpillar OEM Solutions Group, allowing customers the option of purchasing the entire unit through a local Cat dealer.

Configurations are available for 25, 30, 35 or 40 ton articulating truck platforms, using either new long wheelbase trucks, ejector models or existing "tipper" model trucks.

Our Revolutionary design focuses the mass closer to the center of the vehicle, allowing us to improve the stability of the trucks as it is now impossible to off-center the truck due to incorrect loading.

Wabash Folding Staircase



Lowered



Raised

Patent Pending